



xE866 Global Form Factor Application Note

80439NT11318A Rev.2 – 2017-01-02

TELIT
TECHNICAL
DOCUMENTATION

SPECIFICATIONS ARE SUBJECT TO CHANGE WITHOUT NOTICE

NOTICE

While reasonable efforts have been made to assure the accuracy of this document, Telit assumes no liability resulting from any inaccuracies or omissions in this document, or from use of the information obtained herein. The information in this document has been carefully checked and is believed to be reliable. However, no responsibility is assumed for inaccuracies or omissions. Telit reserves the right to make changes to any products described herein and reserves the right to revise this document and to make changes from time to time in content hereof with no obligation to notify any person of revisions or changes. Telit does not assume any liability arising out of the application or use of any product, software, or circuit described herein; neither does it convey license under its patent rights or the rights of others.

It is possible that this publication may contain references to, or information about Telit products (machines and programs), programming, or services that are not announced in your country. Such references or information must not be construed to mean that Telit intends to announce such Telit products, programming, or services in your country.

COPYRIGHTS

This instruction manual and the Telit products described in this instruction manual may be, include or describe copyrighted Telit material, such as computer programs stored in semiconductor memories or other media. Laws in the Italy and other countries preserve for Telit and its licensors certain exclusive rights for copyrighted material, including the exclusive right to copy, reproduce in any form, distribute and make derivative works of the copyrighted material. Accordingly, any copyrighted material of Telit and its licensors contained herein or in the Telit products described in this instruction manual may not be copied, reproduced, distributed, merged or modified in any manner without the express written permission of Telit. Furthermore, the purchase of Telit products shall not be deemed to grant either directly or by implication, estoppel, or otherwise, any license under the copyrights, patents or patent applications of Telit, as arises by operation of law in the sale of a product.

COMPUTER SOFTWARE COPYRIGHTS

The Telit and 3rd Party supplied Software (SW) products described in this instruction manual may include copyrighted Telit and other 3rd Party supplied computer programs stored in semiconductor memories or other media. Laws in the Italy and other countries preserve for Telit and other 3rd Party supplied SW certain exclusive rights for copyrighted computer programs, including the exclusive right to copy or reproduce in any form the copyrighted computer program. Accordingly, any copyrighted Telit or other 3rd Party supplied SW computer programs contained in the Telit products described in this instruction manual may not be copied (reverse engineered) or reproduced in any manner without the express written permission of Telit or the 3rd Party SW supplier. Furthermore, the purchase of Telit products shall not be deemed to grant either directly or by implication, estoppel, or otherwise, any license under the copyrights, patents or patent applications of Telit or other 3rd Party supplied SW, except for the normal non-exclusive, royalty free license to use that arises by operation of law in the sale of a product.

USAGE AND DISCLOSURE RESTRICTIONS

I. License Agreements

The software described in this document is the property of Telit and its licensors. It is furnished by express license agreement only and may be used only in accordance with the terms of such an agreement.

II. Copyrighted Materials

Software and documentation are copyrighted materials. Making unauthorized copies is prohibited by law. No part of the software or documentation may be reproduced, transmitted, transcribed, stored in a retrieval system, or translated into any language or computer language, in any form or by any means, without prior written permission of Telit

III. High Risk Materials

Components, units, or third-party products used in the product described herein are NOT fault-tolerant and are NOT designed, manufactured, or intended for use as on-line control equipment in the following hazardous environments requiring fail-safe controls: the operation of Nuclear Facilities, Aircraft Navigation or Aircraft Communication Systems, Air Traffic Control, Life Support, or Weapons Systems (High Risk Activities"). Telit and its supplier(s) specifically disclaim any expressed or implied warranty of fitness for such High Risk Activities.

IV. Trademarks

TELIT and the Stylized T Logo are registered in Trademark Office. All other product or service names are the property of their respective owners.

V. Third Party Rights







The software may include Third Party Right software. In this case you agree to comply with all terms and conditions imposed on you in respect of such separate software. In addition to Third Party Terms, the disclaimer of warranty and limitation of liability provisions in this License shall apply to the Third Party Right software.

TELIT HEREBY DISCLAIMS ANY AND ALL WARRANTIES EXPRESS OR IMPLIED FROM ANY THIRD PARTIES REGARDING ANY SEPARATE FILES, ANY THIRD PARTY MATERIALS INCLUDED IN THE SOFTWARE, ANY THIRD PARTY MATERIALS FROM WHICH THE SOFTWARE IS DERIVED (COLLECTIVELY "OTHER CODE"), AND THE USE OF ANY OR ALL THE OTHER CODE IN CONNECTION WITH THE SOFTWARE, INCLUDING (WITHOUT LIMITATION) ANY WARRANTIES OF SATISFACTORY QUALITY OR FITNESS FOR A PARTICULAR PURPOSE.

NO THIRD PARTY LICENSORS OF OTHER CODE SHALL HAVE ANY LIABILITY FOR ANY DIRECT, INDIRECT, INCIDENTAL, SPECIAL, EXEMPLARY, OR CONSEQUENTIAL DAMAGES (INCLUDING WITHOUT LIMITATION LOST PROFITS), HOWEVER CAUSED AND WHETHER MADE UNDER CONTRACT, TORT OR OTHER LEGAL THEORY, ARISING IN ANY WAY OUT OF THE USE OR DISTRIBUTION OF THE OTHER CODE OR THE EXERCISE OF ANY RIGHTS GRANTED UNDER EITHER OR BOTH THIS LICENSE AND THE LEGAL TERMS APPLICABLE TO ANY SEPARATE FILES, EVEN IF ADVISED OF THE POSSIBILITY OF SUCH DAMAGES.

APPLICABILITY TABLE (REMOVE UNUSED)

PRODUCTS

-   GE866-QUAD
-   UE866 SERIES
-   LE866 SERIES

CONTENTS

NOTICE	2
COPYRIGHTS	2
COMPUTER SOFTWARE COPYRIGHTS	2
USAGE AND DISCLOSURE RESTRICTIONS	3
I. License Agreements	3
II. Copyrighted Materials	3
III. High Risk Materials	3
IV. Trademarks	3
V. Third Party Rights	3
APPLICABILITY TABLE (REMOVE UNUSED)	4
CONTENTS	5
1. INTRODUCTION	7
2. OVERVIEW	10
3. MECHANICAL DIMENSIONS	11
4. MODULE CONNECTIONS	13
4.1. Common PIN-OUT	13
4.2. PIN-OUT differences	16
4.2.1. USB Port.....	16
4.2.2. Analog Audio	18
4.2.3. GPIO Alternate Functions	18
4.2.4. SIMIN GPIO Input.....	20
4.2.5. SPI Port	20
4.2.6. Antenna Diversity.....	21
4.2.7. RTC.....	22
5. LOGIC LEVEL SPECIFICATIONS	23
5.1. Absolute Maximum Ratings – Not Functional.....	23
5.2. Operating Range – Interface levels (1.8V CMOS).....	23
5.3. Current characteristic.....	24
6. POWER SUPPLY	25
6.1. Power Supply Requirements.....	25
7. DAC AND ADC	27

7.1.	ADC.....	27
7.2.	DAC.....	27
8.	PSM MODE	28
9.	DOCUMENT HISTORY	31

1. INTRODUCTION

1.1. Scope

The aim of this document is the description of some hardware solutions useful for developing an application compatible with the products: Telit GE866, Telit UE866, Telit LE866 and to highlight the minor differences between the above mentioned products.

1.2. Contact Information, Support

For general contact, technical support services, technical questions and report documentation errors contact Telit Technical Support at:

- TS-EMEA@telit.com
- TS-AMERICAS@telit.com
- TS-APAC@telit.com

Alternatively, use:

<http://www.telit.com/support>

For detailed information about where you can buy the Telit modules or for recommendations on accessories and components visit:

<http://www.telit.com>

Our aim is to make this guide as helpful as possible. Keep us informed of your comments and suggestions for improvements.

Telit appreciates feedback from the users of our information.

1.3. Text Conventions



Danger – This information **MUST** be followed or catastrophic equipment failure or bodily injury may occur.



Caution or Warning – Alerts the user to important points about integrating the module, if these points are not followed, the module and end user equipment may fail or malfunction.



Tip or Information – Provides advice and suggestions that may be useful when integrating the module.

All dates are in ISO 8601 format, i.e. YYYY-MM-DD.

1.4. Related Documents

- GE866-QUAD Hardware User Guide, 1VV0301051 Rev. 6
- UE866 Hardware User Guide, 1VV0301157 Rev. 11
- LE866 Hardware User Guide, 1VV0301210 Rev. 5
- LE866 PSM Application Note, 80471NT11483A Rev. 1

2. OVERVIEW

In this document all the basic functions of a mobile phone will be taken into account; for each one of them a proper hardware solution will be suggested and eventually the wrong solutions and common errors to be avoided will be evidenced. Obviously, this document cannot embrace the whole hardware solutions and products that may be designed. The wrong solutions to be avoided shall be considered as mandatory, while the suggested hardware configurations shall not be considered mandatory, instead the information given shall be used as a guide and a starting point for properly developing your product with the described modules. For further hardware details that may not be explained in this document refer to the Telit Product Description documents where all the hardware information is reported.



NOTICE:

The integration of the xE866 cellular module within user application shall be done according to the design rules described in this manual.

The Unified Form Factor (UFF) is a concept of a products family characterized by the same mechanical and electrical form factor with different radio access technology.

This new approach protects customer's investment by giving you the possibility to migrate with the simple plug-and-play switch of your module with other wireless modules in the Unified Form Factor range without changing your application. In this way Telit offers easy access to different cellular technologies, certifications or bandwidth. For example if you develop applications based on today's mobile operator GSM/GPRS cellular technology if required it might be upgraded in the future to higher data speed capability such as UMTS/HSDPA.

The main advantages are summarized below:

- Increase of the efficiency in the use of the investments assigned to the development of the application (NRE), resulting in higher ROI, thus justifying the business choice of the UFF products;
- Products that are designed to bring technology enhancements to the integrators, such as higher data rates and new wireless standards while maintaining backwards compatibility in form factor and logical interfaces;
- Ease of integration;
- Telit as a single supplier of wireless modems;
- The customer can focus on its core business and application, not the management of operations and procurement required for wireless modems;
- One single application for different markets.

Telit, acknowledging the requirements of the developers, has taken great care to minimize any difference in the interface of the products with the Unified Form Factor; nevertheless some minor differences are still present. Differences are mainly due by the fact that different technologies have different electrical and mechanical characteristics, however, the application can, with some care, easily accommodate multiple wireless modems.

This document has been created to guide you when developing applications based on Unified Form Factor concept by pointing out module differences

3. MECHANICAL DIMENSIONS

The Telit xE866 overall dimensions are:

	LENGTH (MM)	WIDTH (MM)	THICKNESS (MM)
GE866	19	15	2.2
UE866	25	15	2.2
LE866	25	15	2.2

In a common design application which is going to use multiple models, we recommend to consider the highest dimensions as reference.

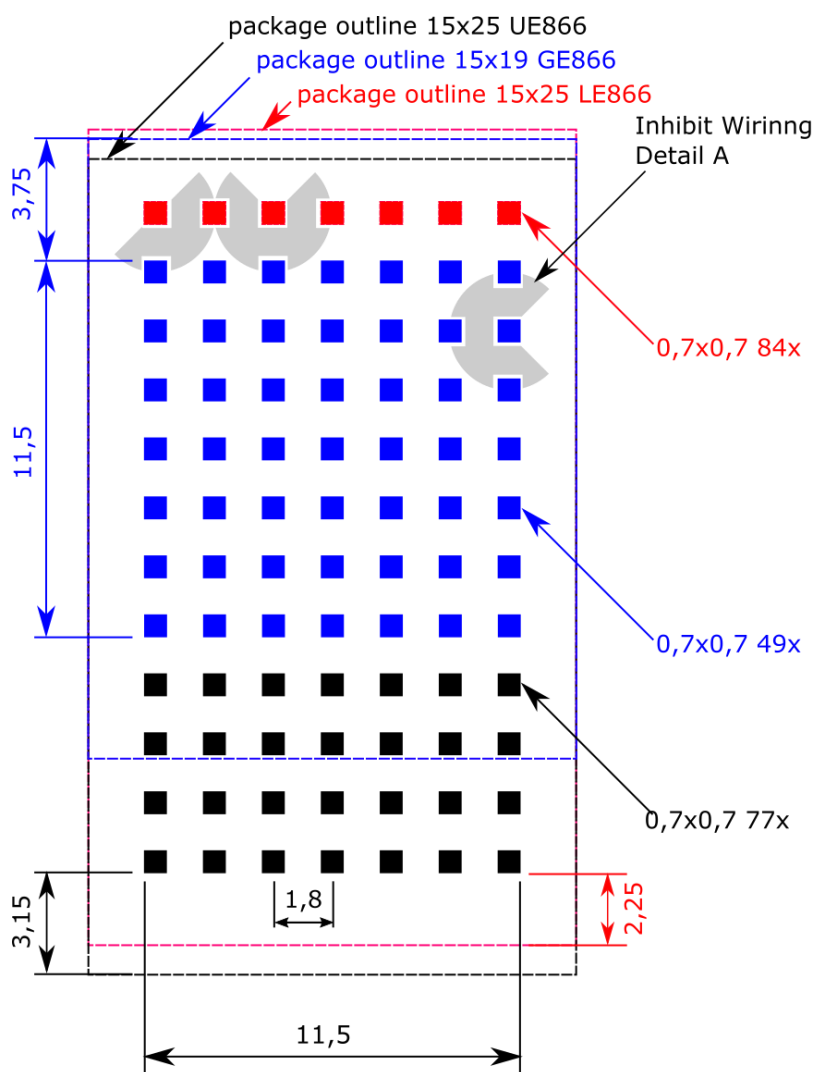

If figure below is indicated the minimum clearance needed in order to have the possibility to mount all xE866 family products (all sizes are in mm):

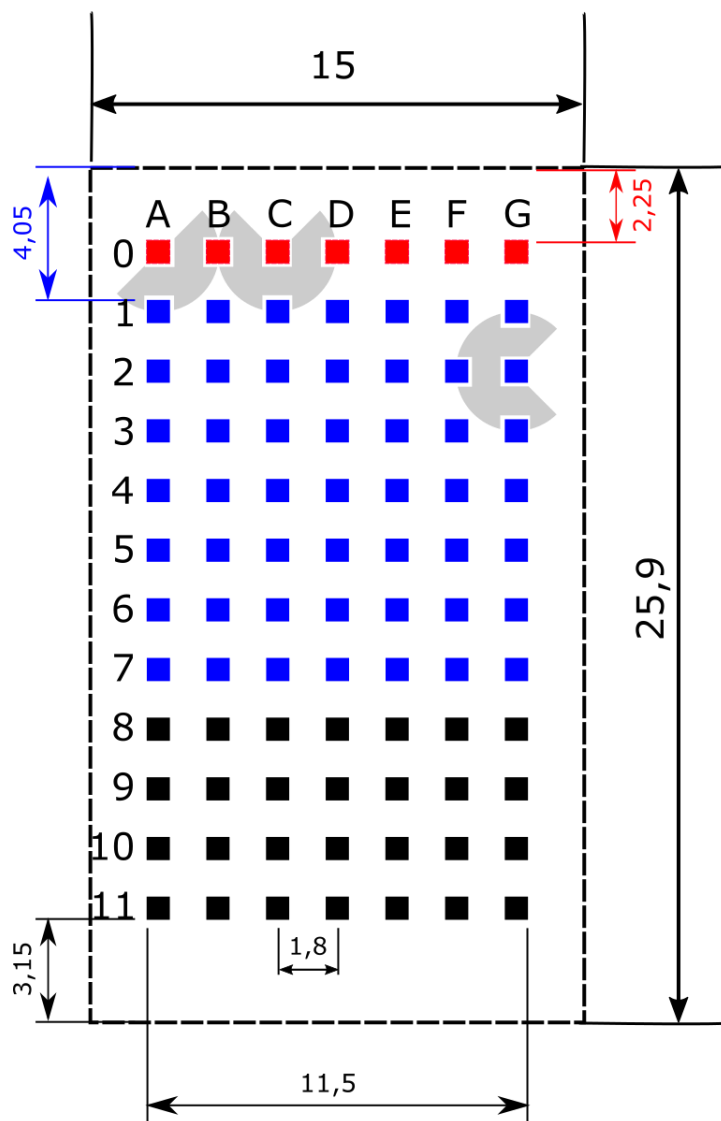

Note that the alignment between the different footprints shall be the A1 pad and not the module mechanical corner.



NOTE:

In order to easily rework the xE866, it is suggested considering on the application 1.5mm placements inhibit area around the module.



NOTE:

The 3D drawings/models versions are available separately and they are provided in IGES format. Please contact the TELIT technical support to get the models.

4. MODULE CONNECTIONS

4.1. Common PIN-OUT

PIN	SIGNAL	I/O	FUNCTION	TYPE	COMMENT
PROG. / DATA + HW FLOW CONTROL					
A4	C103/TXD	I	Serial data input from DTE	CMOS 1.8V	
A5	C104/RXD	O	Serial data output to DTE	CMOS 1.8V	
A2	C108/DTR	I	Input for (DTR) from DTE	CMOS 1.8V	
A1	C105/RTS	I	Input for Request to send signal (RTS) from DTE	CMOS 1.8V	
B1	C106/CTS	O	Output for Clear to Send signal (CTS) to DTE	CMOS 1.8V	
B2	C109/DCD	O	Output for (DCD) to DTE	CMOS 1.8V	
A3	C107/DSR	O	Output for (DSR) to DTE	CMOS 1.8V	
B3	C125/RING	O	Output for Ring (RI) to DTE	CMOS 1.8V	
POWER SUPPLY					
E2	VBATT	-	Main power supply (Baseband)	Power	
E1	VBATT_PA	-	Main power supply (Radio PA)	Power	
SIM CARD INTERFACE					

C7	SIMVCC	-	External SIM signal – Power supply for the SIM	1.8 / 3V
B7	SIMRST	O	External SIM signal – Reset	1.8 / 3V
A6	SIMIO	I/O	External SIM signal - Data I/O	1.8 / 3V
A7	SIMCLK	O	External SIM signal – Clock	1.8 / 3V
Telit GPIOs				
C5	GPIO_01 / DVI_WA0	I/O	Telit GPIO_01 Configurable GPIO/ Digital Audio Interface (WA0)	CMOS 1.8V
C6	GPIO_02 / JDR / DVI_RX	I/O	Telit GPIO_02 Configurable GPIO/ Jammer Detect Report / Digital Audio Interface (RX)	CMOS 1.8V
D6	GPIO_03 / DVI_TX	I/O	Telit GPIO_03 Configurable GPIO/ Digital Audio Interface (TX)	CMOS 1.8V
D5	GPIO_04/ TX Disable / DVI_CLK	I/O	Telit GPIO_04 Configurable GPIO/ TX Disable input / Digital Audio Interface (CLK)	CMOS 1.8V
B5	GPIO_05 / RFTXMON	I/O	Telit GPIO_05 Configurable GPIO/ Transmitter ON monitor	CMOS 1.8V
B4	GPIO_06 / ALARM / BUZZER	I/O	Telit GPIO_06 Configurable GPIO/ ALARM / BUZZER	CMOS 1.8V

C4	GPIO_07 / STAT_LED	I/O	Telit GPIO_07 Configurable GPIO / Status LED	
RF SECTION				
G2	ANTENNA	I/O	GSM/EDGE/UMTS/LTE Antenna (50 Ohm)	RF
MISCELLANEOUS FUNCTIONS				
G6	VAUX/PWRMON	O	1.8V stabilized output I _{max} = 100mA/ Power ON monitor	1.8V
G4	RESET*	I	Reset Input (Active Low)	Connect in Open- Drain
F5	VRTC	-	backup for the embedded RTC supply	
RESERVED				
G5, B6				
GROUND PINS				
D1, F1, G1, D2, F2, C3, E3, F3, G3, F6				



WARNING:
RESERVED pins reported above must not be connected.



NOTE:
The internal GPIO pull-up/pull-down could be set to the preferred status for the application using the AT#GPIO command.
Please refer to the AT Commands User Guide for the detailed command syntax.

4.2. PIN-OUT differences

UE866 has 4 rows of pins more than GE866; LE866 has another row up to row 1 called row 0, see the figures below:

GE866							UE866							LE866							
A	B	C	D	E	F	G	A	B	C	D	E	F	G	A	B	C	D	E	F	G	
C104/RTS	C104/CTS	TXD_AUX	GND	VBATT_PA	GND	GND	C105RTS	C106CTS	TX_AUX	GND	VBATT_PA	GND	GND	0	RESERVED	GND	DIV_ANT	GND	VBATT_PA	GND	GND
C108/DTR	C108/DCD	RX_AUX	GND	VBATT	GND	ANT	C108DTR	C108DCC	RX_AUX	GND	VBATT	GND	ANT	1	C105RTS	C106CTS	TX_AUX	GND	VBATT_PA	GND	GND
C107/DBR	C125/RING	GND	RESERVED	GND	GND	GND	C107DBR	C125RING	GND	RFU	GND	GND	GND	2	C108DTR	C108DCC	RX_AUX	GND	VBATT	GND	MAIN_ANT
C103/TXD	GPIO_04/ALARM/RTS_B	GPIO_07/RTS_A	RESERVED	DAC_OUT	ADC_IN	RESET*	C103TXD	GPIO_06	GPIO_07	USB_VBUS	DAC_OUT	ADC_IN1	RESET*	3	C107DBR	C125RING	GND	PSM_WAKE	GND	GND	GND
C104/RXD	GPIO_05/RTS_B	GPIO_01/CV1_NOD	GPIO_04/RTS_B/SVT_CLK	RESERVED	RFU	RESERVED	C104RXD	GPIO_05	GPIO_01	GPIO_04	USB_D+	VRTC	RESERVED	4	C103TXD	GPIO_06	GPIO_07	RESERVED	DAC_OUT	ADC_IN1	RESET*
SIMIO	RESERVED	GPIO_02/INT_RX	GPIO_01/CV1_TX	RESERVED	AUX0	Y_40V/PSEARCH	SIMIO	RESERVED	GPIO_02	GPIO_03	USB_D-	GND	VAUXPWR_MON	5	C104RXD	GPIO_05	GPIO_01	GPIO_04	USB_D+	RESERVED	RESERVED
SIMCLK	SIMRST	SIMVCC	RESERVED	RESERVED	RESERVED	RESERVED	SIMCLK	SIMRST	SIMVCC	RESERVED	RESERVED	RESERVED	RESERVED	6	SIMIO	RESERVED	GPIO_02	GPIO_03	USB_D-	GND	VAUXPWR_MON
GND	RESERVED	RFU	RFU	RFU	RFU	GND	GND	RESERVED	RFU	RFU	RFU	RFU	GND	7	SIMCLK	SIMRST	SIMVCC	RESERVED	RESERVED	RESERVED	RESERVED
RESERVED	RESERVED	RESERVED	RESERVED	RESERVED	RESERVED	RESERVED	RESERVED	RESERVED	RESERVED	RESERVED	RESERVED	RESERVED	8	GND	RESERVED	RESERVED	VDDIO_IN	PSM_STAT_US	PSM_ENA_OUT	GND	
RESERVED	RESERVED	RESERVED	RESERVED	RFU	RESERVED	RESERVED	RESERVED	RESERVED	RESERVED	RESERVED	RFU	RESERVED	RESERVED	9	RESERVED	RESERVED	RESERVED	RESERVED	RESERVED	RESERVED	RESERVED
RESERVED	RESERVED	RESERVED	RESERVED	RESERVED	RESERVED	RESERVED	RESERVED	RESERVED	RESERVED	RESERVED	RESERVED	RESERVED	RESERVED	10	RESERVED	RESERVED	RESERVED	RESERVED	RESERVED	RESERVED	RESERVED
GND	RESERVED	RESERVED	SPL_MRDY	SPL_SRDY	SPL_CLK	GND	GND	RESERVED	RESERVED	SPL_MRDY	SPL_SRDY	SPL_CLK	GND	11	GND	RESERVED	RESERVED	RESERVED	RESERVED	RESERVED	GND



WARNING:

In case GE866 is mounted don't place solder past on the pins in rows 0 and from 8 to 11; in case UE866 is mounted don't place solder past on row 0.



NOTE:

In order to have a xE866 compatible design you should use a 12 row footprint.



On LE866 pin D8 (VDDIO_IN) shall be externally connected to VAUX (pin G6), in a xE866 common design pin D8 shall be connected to pin G6.

4.2.1. USB Port

The USB port is present in UE866 and LE866, on GE866 the USB port is not present but D4, E5 and E6 pins are unconnected so in a xE866 common design the USB connection can be predisposed and used in case UE/LE866 is mounted. The UE866 and LE866 supports High Speed (480Mb/s) mode, for this reason the signal traces should be routed

carefully: trace lengths, number of vias and capacitive loading should be minimized and the characteristic impedance value should be as close as possible to 90 Ohms differential.

USB can be used for the following purposes: communication with external peripheral devices, debug monitor.

The following table is listing the available signals:

PIN	SIGNAL	I/O	FUNCTION	TYPE	COMMENT
USB HS 2.0 Communication Port					
E5	USB_D+	I/O	USB differential Data (+)		Unconnected on GE866
E6	USB_D-	I/O	USB differential Data (-)		Unconnected on GE866
D4	VUSB	I	Power sense for the internal USB transceiver.		Unconnected on GE866

VUSB pin is present on all modems supporting USB. It must be connected to +5V in order to activate the USB port.

For more information about USB port, refer to the Hardware User Guide.



We recommend adding USB PCB connector pads for convenient access for network certification testing, firmware upgrade and module debug logs. The USB connector can be “DNP” until needed. This may be more convenient than just test points alone.

4.2.2. Analog Audio

On GE866 an analog audio front-end port is present, the pinout is indicated in the following table:

PIN	SIGNAL	I/O	FUNCTION	TYPE	COMMENT
Analog Voice Interface					
D7	EAR+	AO	Ear signal output, phase +		
E7	EAR-	AO	Ear signal output, phase +		
F7	MIC+	AI	Microphone signal input; phase +		
G7	MIC-	AI	Microphone signal input; phase -		



On LE866 and UE866 the analog audio interface is not present. In a xE866 common design you should use the digital audio interface.

4.2.3. GPIO Alternate Functions

On the different xE866 family modems not all the alternate functions are implemented.

See table below to verify the Alternate function availability on the various products.

In a xE866 common design you should avoid using the Alternate functions not available in all the products such as JDR, TX Disable, RFTXMON and BUZZER.

PIN	SIGNAL	I/O	FUNCTION	AVAILABILITY
GPIO				
C5	GPIO_01 / DVI_WA0	I/O	Telit GPIO_01 Configurable GPIO/ Digital Audio Interface (WA0)	-
C6	GPIO_02 / JDR / DVI_RX	I/O	Telit GPIO_02 Configurable GPIO/ Jammer Detect Report / Digital Audio Interface (RX)	JDR NOT Available on LE866
D6	GPIO_03 / DVI_TX	I/O	Telit GPIO_03 Configurable GPIO/ Digital Audio Interface (TX)	-
D5	GPIO_04/ TX Disable / DVI_CLK	I/O	Telit GPIO_04 Configurable GPIO/ TX Disable input / Digital Audio Interface (CLK)	TX Disable NOT Available on UE866 and LE866
B5	GPIO_05 / RFTXMON	I/O	Telit GPIO_05 Configurable GPIO/ Transmitter ON monitor	RFTXMON NOT Available on UE866 and LE866
B4	GPIO_06 / ALARM / BUZZER	I/O	Telit GPIO_06 Configurable GPIO/ ALARM / BUZZER	BUZZER NOT Available on UE866 and LE866
C4	GPIO_07 / STAT_LED	I/O	Telit GPIO_07 Configurable GPIO / Status LED	-

4.2.4. SIMIN GPIO Input

On the xE866 modems the SIMIN feature is not bounded to a particular I/O, but instead it can be configured on one of the GPIOs available, provided no other function is used on that I/O. Not all the GPIO are available as SIMIN sources in all products, see table below:

GPIO AVAILABLE FOR SIMIN	
GE866	ALL
UE866	ONLY GPIO_06/ GPIO_07
LE866	ALL

In a xE866 common design you should tie the SIMIN function to either GPIO_06 or GPIO_07.

4.2.5. SPI Port

Only UE866 is provided by an SPI hardware interface that shares the hardware resources with the AUX_UART port. To use either AUX_UART or SPI an AT port configuration command must be sent. It shall be noted that by default the hardware SPI port of the module differs from the standard SPI. This interface supports two handshake lines for flow control and mutual wake-up: SRDY (slave ready) and MRDY (master ready). The application has the master role, that is, it supplies the clock.

PIN	SIGNAL	I/O	FUNCTION	TYPE	COMMENT
SPI					
C1	SPI_MOSI	I	SPI MOSI	CMOS 1.8V	Shared with TX_AUX
C2	SPI_MISO	O	SPI_MISO	CMOS 1.8V	Shared with RX_AUX
F11	SPI_CLK	I	SPI Clock	CMOS 1.8V	Shared with HSIC_HOST_WAKEUP
D11	SPI_MRDY	I	SPI_MRDY	CMOS 1.8V	Shared with HSIC_SLAVE_WAKEUP
E11	SPI_SRDY	O	SPI_SRDY	CMOS 1.8V	Shared with HSIC_HOST_ACTIVE

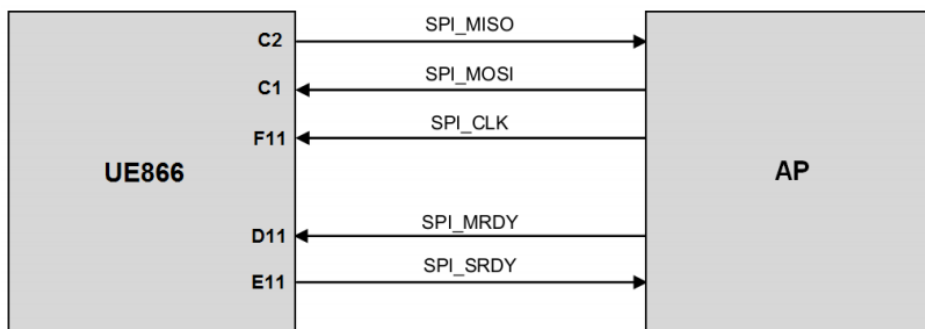

WARNING:

In a common xE866 design the SPI port should be not used.



NOTE:

Due to shared functions, when the SPI port is used, it's not possible to use the AUX_UART port.

For more information, see UE866 Hardware User Guide.

4.2.6. Antenna Diversity

On LE866 is included an input for a second RX antenna to improve the radio sensitivity. The function is called Antenna Diversity. In a xE866 common design in order to have the possibility to use the diversity antenna when LE866 is mounted you should route the diversity antenna connection to C0 pad.

PIN	SIGNAL	I/O	FUNCTION	TYPE	COMMENT
RF SECTION					
C0	ANT_DIV	I	Antenna Diversity Input (50 ohm)	RF	



As of dec. 2014, PTCRB updated PPMD document section 11.10.6 Feature/Function Set for Integrated Devices, and in the last revision the Diversity is not anymore among the exception features that may not match the modem capabilities. This means that if the assembled modem supports Diversity antenna, then in order to get PTCRB approval (and subsequent US carrier approval) the application MUST have a diversity antenna.



NOTE:

If the RX Diversity is not used/connected, disable the Diversity functionality using the AT#RXDIV command (ref to the AT User guide for the proper syntax) and leave the pad C0 unconnected.

4.2.7. RTC

The xE866 modems internally provide a real time clock.

On the GE866, UE866 the supply of the RTC is separate from the rest of the digital parts, allowing having only RTC running when all other parts of the device are off. This supply is connected to pin VRTC and a backup capacitor can be added in order to increase the RTC autonomy during power off of the main supply. No devices must be powered from this pin.

The internal RTC on LE866 is powered directly from VBATT, there is no VRTC separate voltage like in the other products of the xE866 family; so in order to keep the RTC running, VBATT should not be removed.

In a xE866 common design, the VRTC pin should not be used and if RTC always running is a requirement then VBATT signal shall be backed up.

PIN	SIGNAL	I/O	FUNCTION	TYPE	COMMENT
RTC					
F5	VRTC	AO	Backup for the embedded RTC supply	-	



WARNING:

In a common xE866 design the VRTC pin should be not used.

5. LOGIC LEVEL SPECIFICATIONS

5.1. Absolute Maximum Ratings – Not Functional

INPUT LEVEL ON ANY DIGITAL PIN (CMOS 1.8V) WITH RESPECT TO GROUND		
	MIN	MAX
GE866	-0.3V	2.1V
UE866	-0.3V	2.1V
LE866	-0.3V	VDDIO_IN + 0.3V
LE866 when VDDIO is not supplied	-0.3V	0.3V



NOTE:

On LE866 VDDIO_IN shall be within the range 1.7V – 1.9V, hence the MAX voltage on any digital pin for the LE866 is in the range 2.0V – 2.1V.

5.2. Operating Range – Interface levels (1.8V CMOS)

	Input High Level		Input Low Level		Output High Level		Output Low Level	
	Min	Max	Min	Max	Min	Max	Min	Max
GE866	1.3V	1.9V	0.0V	0.35V	1.6V	1.9V	0.0V	0.2V
UE866	1.5V	1.9V	0.0V	0.35V	1.6V	1.9V	0.0V	0.2V
LE866	1.5V	1.9V	0.0V	0.35V	1.6V	1.9V	0.0V	0.2V

5.3. Current characteristic

	OUTPUT CURRENT	INPUT CURRENT
GE866	1mA	1 μ A
UE866	1mA	1 μ A
LE866	1mA	1 μ A

6. POWER SUPPLY

The power supply circuitry and board layout are a very important part in the full product design and they strongly reflect on the product overall performances, hence read carefully the requirements and the guidelines that will follow for a proper design.

To improve EMI filtering an EMI suppression circuitry must be added on modem's VBATT_PA, and if possible also on VBATT. Follow schematic on figure below.

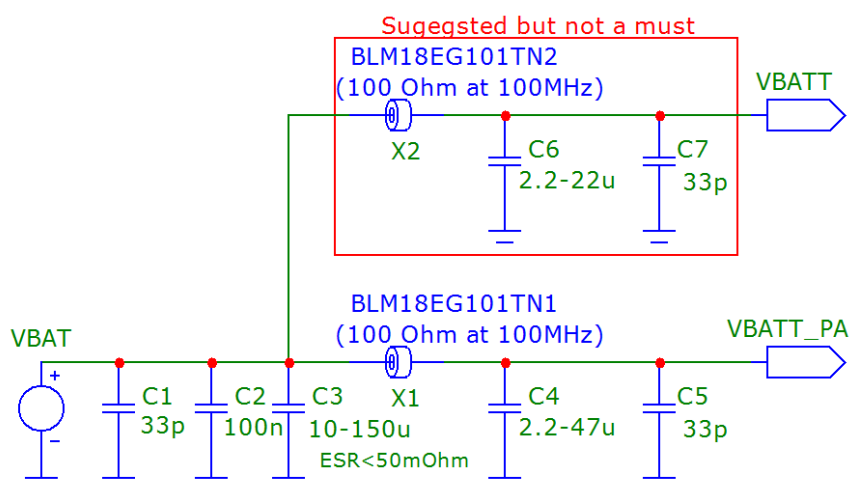

6.1. Power Supply Requirements

The external power supply must be connected to VBATT & VBATT_PA signals and must fulfill the following requirements:

	NOMINAL SUPPLY VOLTAGE	NORMAL OPERATING VOLTAGE RANGE	EXTENDED OPERATING VOLTAGE RANGE
GE866	3.8V	3.40V - 4.20V	3.10V* - 4.50V
UE866	3.8V	3.40V - 4.20V	3.10V* - 4.50V
LE866	3.8V	3.40V - 4.20V	3.10V - 4.50V



*On UE866 and GE866 the Power supply must be higher than 3.22 V to power on the module, when the module is ON the voltage level on VBATT can go to 3.1V.



The Operating Voltage Range MUST never be exceeded; care must be taken in order to fulfil min/max voltage requirement.



Overshoot voltage (regarding MAX Extended Operating Voltage) and drop in voltage (regarding MIN Extended Operating Voltage) MUST never be exceeded;

The “Extended Operating Voltage Range” can be used only with completely assumption and application of the HW User guide suggestions.



The electrical design for the Power supply should be made ensuring it will be capable of a peak current output of at least 2 A.



For a xE866 common design the voltage level of the power supply should stay in the **Normal Operating voltage Rate**.



In order to avoid latch-up issues we recommend particular care be taken such that no digital pins connected to the modem of the modem remain high when the modem is turned off.

7. DAC AND ADC

7.1. ADC

On GE866, UE866 and LE866 is available an ADC input useful mainly for antenna detection purposes (pin F4). The following table is showing the ADC characteristics for the GE866, UE866 and LE866:

MODULE	Input Voltage range		AD conversion	Resolution	Input Resistance
	MIN	MAX	BIT	MAX	MIN
GE866	0.0V	1.2V	10	1.17mV	1MΩ
UE866	0.0V	1.2V	10	1.17mV	1MΩ
LE866	0.0V	1.0V	10	1mV	1MΩ

7.2. DAC

The GE866, UE866 and LE866 provides a Digital to Analog Converter. The signal (named DAC_OUT) is available on pin E4.

The on board DAC is a 10 bit converter, able to generate an analogue value based on a specific input in the range from 0 up to 1023. However, an external low-pass filter is necessary

The following table is showing the DAC characteristics that are the same for all the xE866 modules:

	MIN	MAX	UNIT
Voltage range (filtered)	0	1.8	Volt
Range	0	1023	Steps

For more information see the DAC Converter chapter on xE866 Hardware User Guides.

8. PSM MODE

The LE866 includes unique advanced features in order to support the PSM according to 3GPP Rel-12 for this purpose the LE866 has 3 dedicated pins:

PIN	SIGNAL	I/O	FUNCTION	TYPE
D3	PSM_WAKE	I	WAKE UP FROM PSM MODE	ANALOG
E8	PSM_STATUS	O	PSM STATUS	CMOS 1.8V
F8	PSM_ENA_OUT	O	PSM ENABLE FOR EXTERNAL LDO	CMOS 1.8V

On GE866 and UE866 those pins are internally unconnected so in a xE866 family common design you can predispose the interconnections in order to have the possibility to use the PSM features when the LE866 is mounted:

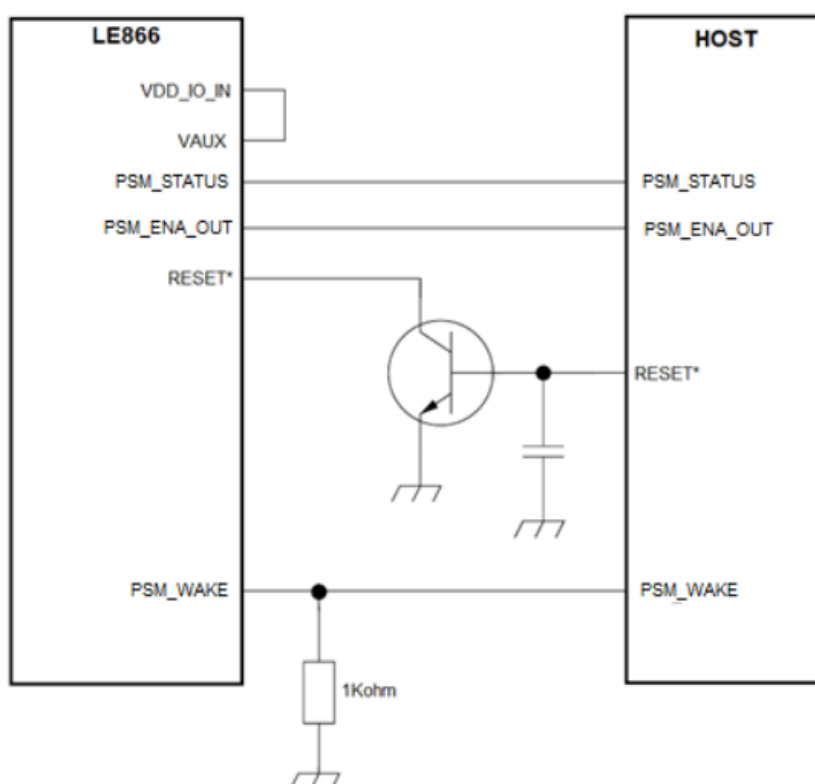



NOTE:

VDDIO_IN can be directly supplied from VAUX_PWRMON line (adding an R0 in series for debug purposes)



NOTE:

If VDDIO_IN line is not powered (i.e. during the sleep states in PSM=2 when supplied by VAUX, during transition phases BOOT, RESET etc. and when the module is unsupplied) it is important to avoid back powering the digital pins. Exceeding the absolute maximum ratings could damage permanently the module.

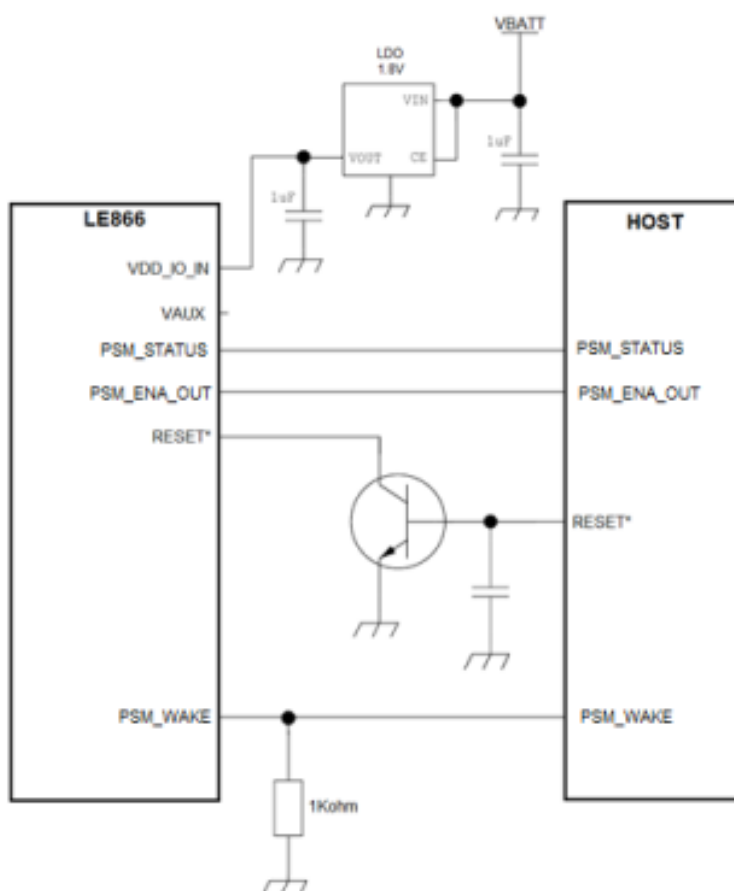

9. DOCUMENT HISTORY

Revision	Date	Changes
0	2014-11-05	First issue
1	2015-06-24	Added LE866
2	2017-01-02	New document layout New note in 4.2 New chapter 8 New Paragraphs 4.2.3 and 4.2.6 Fix the PIN number, in Chapter 4.1



SUPPORT INQUIRIES

Link to www.telit.com and contact our technical support team for any questions related to technical issues.

www.telit.com



Telit Communications S.p.A.
Via Stazione di Prosecco, 5/B
I-34010 Sgonico (Trieste), Italy

Telit Wireless Solutions Inc.
3131 RDU Center Drive, Suite 135
Morrisville, NC 27560, USA

Telit Wireless Solutions Ltd.
10 Habarzel St.
Tel Aviv 69710, Israel

Telit IoT Platforms LLC
5300 Broken Sound Blvd, Suite 150
Boca Raton, FL 33487, USA

Telit Wireless Solutions Co., Ltd.
8th Fl., Shinyoung Securities Bld.
6, Gukjegeumyung-ro8-gil, Yeongdeungpo-gu
Seoul, 150-884, Korea

Telit Wireless Solutions
Tecnologia e Servicos Ltda
Avenida Paulista, 1776, Room 10.C
01310-921 São Paulo, Brazil

Telit reserves all rights to this document and the information contained herein. Products, names, logos and designs described herein may in whole or in part be subject to intellectual property rights. The information contained herein is provided "as is". No warranty of any kind, either express or implied, is made in relation to the accuracy, reliability, fitness for a particular purpose or content of this document. This document may be revised by Telit at any time. For most recent documents, please visit www.telit.com

Copyright © 2016, Telit

Mod. 0809 2016-08 Rev.7