

Antenna Detection Application Note

80000NT10002a Rev. 7 – 2015-06-24



Notice

While reasonable efforts have been made to assure the accuracy of this document, Telit assumes no liability resulting from any inaccuracies or omissions in this document, or from use of the information obtained herein. The information in this document has been carefully checked and is believed to be entirely reliable. However, no responsibility is assumed for inaccuracies or omissions. Telit reserves the right to make changes to any products described herein and reserves the right to revise this document and to make changes from time to time in content hereof with no obligation to notify any person of revisions or changes. Telit does not assume any liability arising out of the application or use of any product, software, or circuit described herein; neither does it convey license under its patent rights or the rights of others.

It is possible that this publication may contain references to, or information about Telit products (machines and programs), programming, or services that are not announced in your country. Such references or information must not be construed to mean that Telit intends to announce such Telit products, programming, or services in your country.

Copyrights

This instruction manual and the Telit products described in this instruction manual may be, include or describe copyrighted Telit material, such as computer programs stored in semiconductor memories or other media. Laws in the Italy and other countries preserve for Telit and its licensors certain exclusive rights for copyrighted material, including the exclusive right to copy, reproduce in any form, distribute and make derivative works of the copyrighted material. Accordingly, any copyrighted material of Telit and its licensors contained herein or in the Telit products described in this instruction manual may not be copied, reproduced, distributed, merged or modified in any manner without the express written permission of Telit. Furthermore, the purchase of Telit products shall not be deemed to grant either directly or by implication, estoppel, or otherwise, any license under the copyrights, patents or patent applications of Telit, as arises by operation of law in the sale of a product.

Computer Software Copyrights

The Telit and 3rd Party supplied Software (SW) products described in this instruction manual may include copyrighted Telit and other 3rd Party supplied computer programs stored in semiconductor memories or other media. Laws in the Italy and other countries preserve for Telit and other 3rd Party supplied SW certain exclusive rights for copyrighted computer programs, including the exclusive right to copy or reproduce in any form the copyrighted computer program. Accordingly, any copyrighted Telit or other 3rd Party supplied SW computer programs contained in the Telit products described in this instruction manual may not be copied (reverse engineered) or reproduced in any manner without the express written permission of Telit or the 3rd Party SW supplier. Furthermore, the purchase of Telit products shall not be deemed to grant either directly or by implication, estoppel, or otherwise, any license under the copyrights, patents or patent applications of Telit or other 3rd Party supplied SW, except for the normal non-exclusive, royalty free license to use that arises by operation of law in the sale of a product.



APPLICABILITY TABLE

	SW Versions
GC Family (Compact)	
GC864-QUAD	10.00.xx2
GC864-QUAD V2	
GC864-DUAL V2	
GE/GL Family (Embedded)	
GE864-QUAD	10.00.xx2
GE864-QUAD V2	
GE864-QUAD Automotive V2	
GE864-QUAD ATEX	
GE864-DUAL V2	
GE864-GPS	
GE865-QUAD	10.00.xx4
GL865-DUAL	
GL865-QUAD	
GL868-DUAL	13.00.xx3
GE910-QUAD	
GE910-GNSS	
GL865-DUAL V3	16.00.xx2
GL868-DUAL V3	
GE910-QUAD V3	
GE910-QUAD V3	
HE910 Family	
HE910 ¹	12.00.xx3
HE910-GL	
HE910-D	
HE910-EUR/ HE910-EUD	
HE910-EUG/ HE910-NAG	
HE910-NAR/ HE910-NAD	
UE910 Family	
UE910-EUR / UE910-EUD	12.00.xx4
UE910-NAR / UE910-NAD/ UE910-N3G	
GT Family (Terminal)	
GT863-PY	10.00.xx2
GT864-QUAD	
GT864-PY	
LE910 Family	
LE910-EUG	17.00.xx1
LE910-NAG	
LE920 Family	
LE920-EU Auto	17.00.xx1
LE920-NA Auto	

Note: the features described in the present document are provided by the products equipped with the software versions equal or higher than the versions shown in the table.

¹ HE910 is the “type name” of the products marketed as HE910-G & HE910-DG.



1. Introduction

1.1. Scope

This application note outlines the limitations and boundaries of antennas detection and diagnosing, specifically in relation to the automotive environment.

1.2. Audience

This document is intended for Telit customers, who are integrators, mainly of automotive applications.

1.3. Contact Information, Support

For general contact, technical support, to report documentation errors and to order manuals, contact Telit's Technical Support Center (TTSC) at:

TS-EMEA@telit.com

TS-NORTHAMERICA@telit.com

TS-LATINAMERICA@telit.com

TS-APAC@telit.com

Alternatively, use:

<http://www.telit.com/en/products/technical-support-center/contact.php>

For detailed information about where you can buy the Telit modules or for recommendations on accessories and components visit:

<http://www.telit.com>

To register for product news and announcements or for product questions contact Telit's Technical Support Center (TTSC).

Our aim is to make this guide as helpful as possible. Keep us informed of your comments and suggestions for improvements.

Telit appreciates feedback from the users of our information.



1.4. Document Organization

This document contains the following chapters:

Chapter 1: “Introduction” provides a scope for this document, target audience, contact and support information, and text conventions.

Chapter 2: “Antenna Detection”

Chapter 3: “Application Reference Circuitry “

Chapter 4: “Detection Limits”

Chapter 5: “AT commands interface and Algorithms”

1.5. Text Conventions



Danger – This information MUST be followed or catastrophic equipment failure or bodily injury may occur.



Caution or Warning – Alerts the user to important points about integrating the module, if these points are not followed, the module and end user equipment may fail or malfunction.



Tip or Information – Provides advice and suggestions that may be useful when integrating the module.

All dates are in ISO 8601 format, i.e. YYYY-MM-DD.



1.6. Related Documents

- GC864 Hardware User Guide, 1vv0300733
- GE863 Family Hardware User Guide, 1vv0300783
- GE864 Hardware User Guide, 1vv0300694
- GE865 Hardware User Guide, 1vv0300799
- GL865-DUAL V3 Hardware User Guide, 1vv0301018
- HE910 Hardware User Guide, 1vv0300925
- UE910 Hardware User Guide, 1vv0301012
- GE910 Hardware User Guide, 1vv0300962
- LE910 Hardware User Guide, 1vv0301089
- LE920 Hardware User Guide, 1vv0301026
- AT Commands Reference Guide, 80000ST10025a
- HE910 AT Commands Reference Guide, 80000ST10091a
- LE9x0 AT Commands Reference Guide 80407ST10116a

1.7. Document History

Revision	Date	Changes
ISSUE#0	2007-11-12	Initial release
ISSUE#1	2008-10-14	Extended applicability to GE864-QUAD Automotive Revision of document layout
ISSUE#2	2009-01-16	Extended applicability to GE863-SIM
ISSUE#3	2009-05-29	Applied the new layout Added GE865 in the applicability table
ISSUE#4	2010-10-04	Added GL865-DUAL to the applicability table
ISSUE#5	2012-03-12	AT command change on AT #GSMAD
ISSUE#6	2013-07-02	Added HE910, UE910, GE910, GL865 V3; updated schematics and examples; AT commands linked to AT commands Reference Guide
ISSUE#7	2015-06-24	Added LE920, LE910, UE910-N3G, HE910-GL in the applicability table (removed HE910-GA)



Antenna Detection Application Note
80000NT10002a Rev. 7 – 2015-06-24



2. Antenna Detection

Being able to detect and diagnose the antenna is a valuable feature for many system integrators, and especially so for automotive applications. The ability to detect if the antenna is connected to the application is useful, for diagnosing installation or production problems as well as any tampering with the system.

Many automotive applications also have the need to detect if the antenna is shorted to ground or the battery of the vehicle for fault tracing. Basically, antenna detection is performed by means of its DC characteristics, splitting the DC and RF paths.

Two slightly different hardware solutions are here presented: the first one is suitable to be used in conjunction with the antenna detection AT command, i.e. `AT#GSMAD`, thus simplifying application firmware.

The second solution gives a higher flexibility degree to system integrator, permitting a better adaptation to application characteristics and behaviour. In this case the detection algorithm is implemented by customer, consisting of a short sequence of AT commands, performing actual measurements and reporting antenna status.

In addition, two different antenna cases are studied: the first one takes into account an antenna presenting zero DC impedance. The second case considers an antenna showing open circuit to DC signals, so that, in order to detect antenna presence, a 10K Ω nominal value resistor has to be embedded in parallel to antenna.

In all cases, a few simple and low cost passive components are added to the RF path and connected to module IO's.

This application note also outlines the limitations and boundaries of this feature, specifically in relation to the automotive environment. This feature can be implemented on the products containing the Antenna Detection function as noted in the "AT Commands Reference Guide".



3.1. 10KΩ DC terminated antenna detection with AT#GSMAD

The following assumes that the application is using a 10KΩ DC terminated antenna. The figure below outlines the reference implementation, please keep in mind that these components are in the RF path and care must be taken when implementing this circuit, and refer to the “Hardware User Guide” of the actual wireless modem used for more information on this subject.

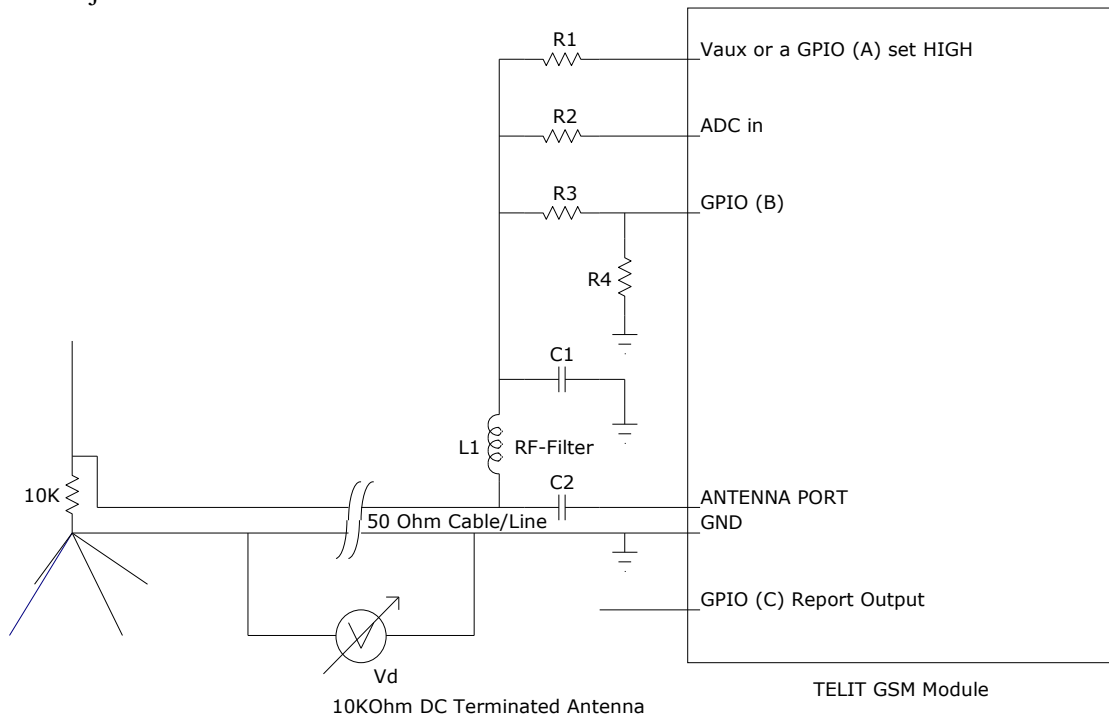

Figure 3.1, Antenna Diagnostics reference schematic for resistive termination, Solution 1

As per **Group 1** products, the V_{aux} is a 2V8 regulated power source output from the module. ADC is a 0÷2000mV 11-bit Analog to Digital Converter input. When GPIO (A) is used as reference instead of V_{aux} (e.g. GE864-QUAD Automotive), the selected GPIO (A) must be chosen among the available ones for the product and must be set as Output HIGH with the specific GPIO AT command.



Antenna Detection Application Note
80000NT10002a Rev. 7 – 2015-06-24

VD represents the offset voltage between antenna and module grounds. The GPIO (B) and GPIO (C) must be defined among the available ones for the product and set into the specific AT command (see **AT#GSMAD parameters <detGPIO>, <repGPIO>**).

This example assumes the use of the “ADC1” input and **GPIO13** port of the module for this purpose.



Same topology depicted on Figure 3.1 may be used on **Group 2** modules. Of course, the AT#GSMAD command implemented into this group takes into account the different V_{aux} , GPIO and ADC levels/intervals of those found in Group 1 modules, so that those differences are totally transparent to final user.

Recommended component values for Figure 1 circuit are the same for both Group 1 and 2 products and are defined in Table 3.1.

Component	Value	Recommended package
R1=R2	15 K Ω	
R3	15 K Ω	
R4	5.6 K Ω	
L1	47 nH	0402 or 0603
C1	33 pF 50V	0402 or 0603
C2	33 pF 50V	0402 or 0603

Table 3.1, recommended component values for Figure 3.1 circuit



3.2. DC grounded antenna with custom detection algorithm

Some antennas show zero ohm impedance to DC. In such cases, two different DC conditions are detectable, only: SHORT = antenna is present and OPEN = antenna is missing.

The circuit solution on Figure 3.1 and the AT#GSMAD may still be used, keeping in mind that an answer “SHORT” means “Antenna is present”.

A second topology is here presented, slightly simpler than the first one. It uses less module hardware resources and it gives the possibility to the user to customize the detection algorithm. Figure 3.2 depicts the proposed circuit, please keep in mind that these components are in the RF path and care must be taken when implementing this circuit, and refer to the “Hardware User Guide” of the actual wireless modem used for more information on this subject.

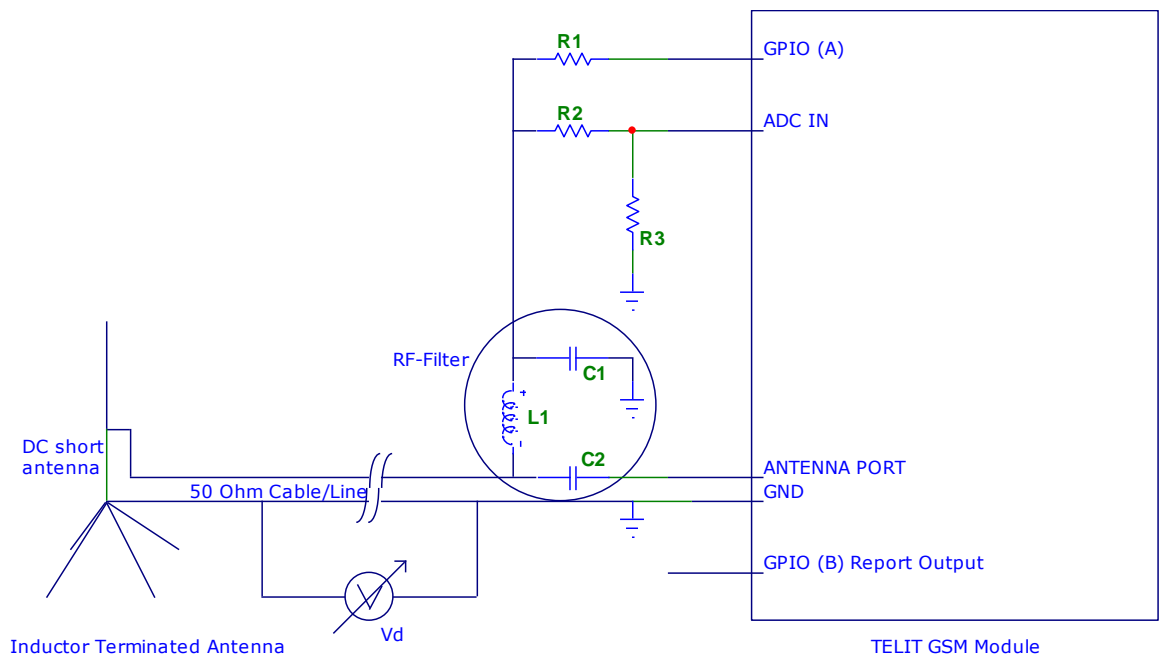

Figure 3.2, Antenna Diagnostics reference schematic for DC grounded configuration

GPIO (A) and GPIO (B) must be chosen among the available General Purpose IO’s. Their high level value is 2V8 (1V8) for **Group 1 (Group 2)** products. Vd represents the offset voltage between antenna and module grounds. Antenna presence is detected by setting GPIO (A) to output high. Voltage level at ADC IN will indicate the antenna status:

- a) If ADC IN next to 0V → antenna is PRESENT
- b) If ADC IN next to 1V8 (1V2) → an OPEN condition is reported, antenna is missing.

AD converter saturates at 2V (1V2): for this reason the (R2, R3) voltage divider is provided.

GPIO (B) is set as output, reporting an antenna good or fault condition.

For components values please refer to Table 3.2 in chapter 3.3.

A reference algorithm for antenna detection may be found in chapter 5.2.



3.4. PCB layout recommendations

The C1-L1-C2 RF-Filter has to be compact and near the transmission line; particularly: the capacitor C2 has to be along the antenna transmission line, the inductor L1 has to be very close to transmission line, the capacitor C1 has to be next to L1. See example below.

This RF-filter is a network that decouples the DC from RF-signal (Bias-Tee): C2 let flow the RF signal between M2M module and the antenna, L1 picks just the DC voltage up and C1 further blocks RF to get into the remainder of the circuitry.

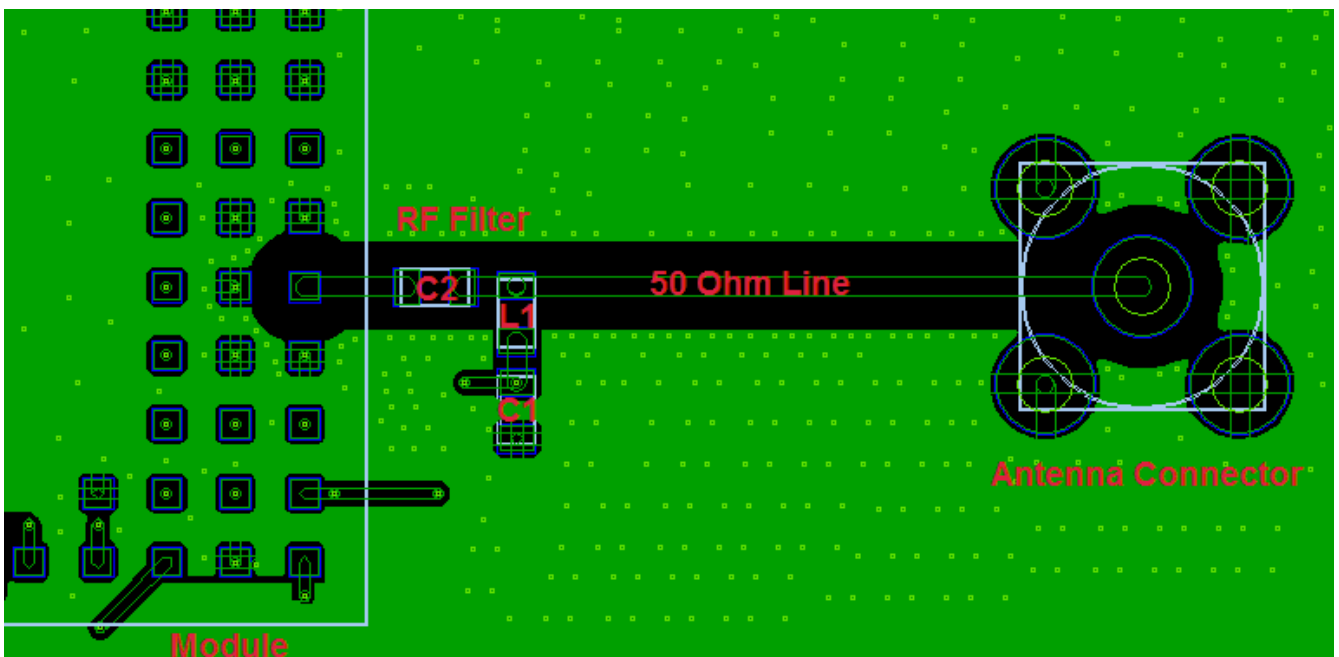

RF-filter layout example



4. Detection limits

4.1. 10K Ω DC terminated antenna detection with AT#GSMAD

Referring to chapter 3.1, the detection algorithm checks if the “DC-resistance” of the antenna to ground path is compatible with a 10 K resistor within 5% tolerance. For Group 1 modules it is also capable to compensate an antenna ground offset V_d between -800mV and +800mV. Please note that for Group 2 products, the V_d compensation interval is [-800mV, +560mV]. If a $\pm 0.8V$ interval is required, then consider the solution presented at chapter 3.3.

If the “DC-resistance” of the antenna to ground path is compatible with a 10 K resistor within 5% tolerance, the antenna is correctly connected and detected. Otherwise, if DC-resistance is significantly less, the cable or antenna port is shorted; if it is much greater, the cable or antenna port is open (i.e. cut or unconnected wire). If the DC voltage read is stuck high, it means that the antenna terminal is in contact with a voltage source (for example a vehicle battery).

Please note that most automotive systems are specified to work with a ground offset of no more than $\pm 0.8V$. A ground offset that normally is above $\pm 0.8V$ may be an indication of a severe fault condition in the application wiring or connection with the antenna, e.g. high contact resistance, a broken or strained cable shield or a stray current due to a ground fault. Under these circumstances, the RF performance of the antenna may also be adversely affected.

4.2. DC grounded antenna with custom detection algorithm

As per chapter 3.2, the detection algorithm checks if the antenna shows a short circuit, meaning the antenna is present, or an open circuit, indicating the antenna is missing. Unfortunately, due to antenna zero DC impedance, the external voltage source contact with antenna is not detectable; neither a short circuit between antenna terminals cannot be detected, due to fact an antenna cable short cannot be distinguished from the antenna intrinsic DC short.



4.3. 10K Ω DC terminated antenna with custom detection algorithm

Solution at chapter 3.3 checks if the “DC-resistance” of the antenna to ground path is compatible with a 10 K resistor within 5% tolerance.

If this is the case, the antenna is correctly connected and detected. Otherwise, if DC-resistance is significantly less, the cable or antenna port is shorted; if it is much greater, the cable or antenna port is open (i.e. cut or unconnected wire). If the DC voltage read is stuck high, it means that the antenna terminal is in contact with a voltage source (for example a vehicle battery).

For both Group 1 and 2 modules, the proposed circuit and algorithm at chapter 5.3 is capable of Vd compensation in the [-800mV, +800mV] interval. Besides, the proposed algorithm is for reference only and it may be customized in order to be suitable to specific antenna and application configurations.



5. AT Command Interface and algorithms

5.1. AT Commands

The module is provided by a set of commands that could be used with the Antenna Detection application.

The main command is AT#GSMAD that could be used with the application example described in chapter 3.1.

The other commands are AT#ADC and AT#GPIO that could be used with the application examples described in chapters 3.2 and 3.3.

The following two chapters are describing the related algorithms.

All the details on the above commands are described in the AT Commands Reference Guides (see chapter 1.6 for the list of the available documents).



5.2. DC grounded antenna Algorithm

If the chapter 3.2 topology is used for a DC grounded antenna detection, its algorithm may be easily implemented by sending few AT commands to module, as per following flow chart. ZERO_DC_THR is equal to 600mV for all products (both Group1 and 2).

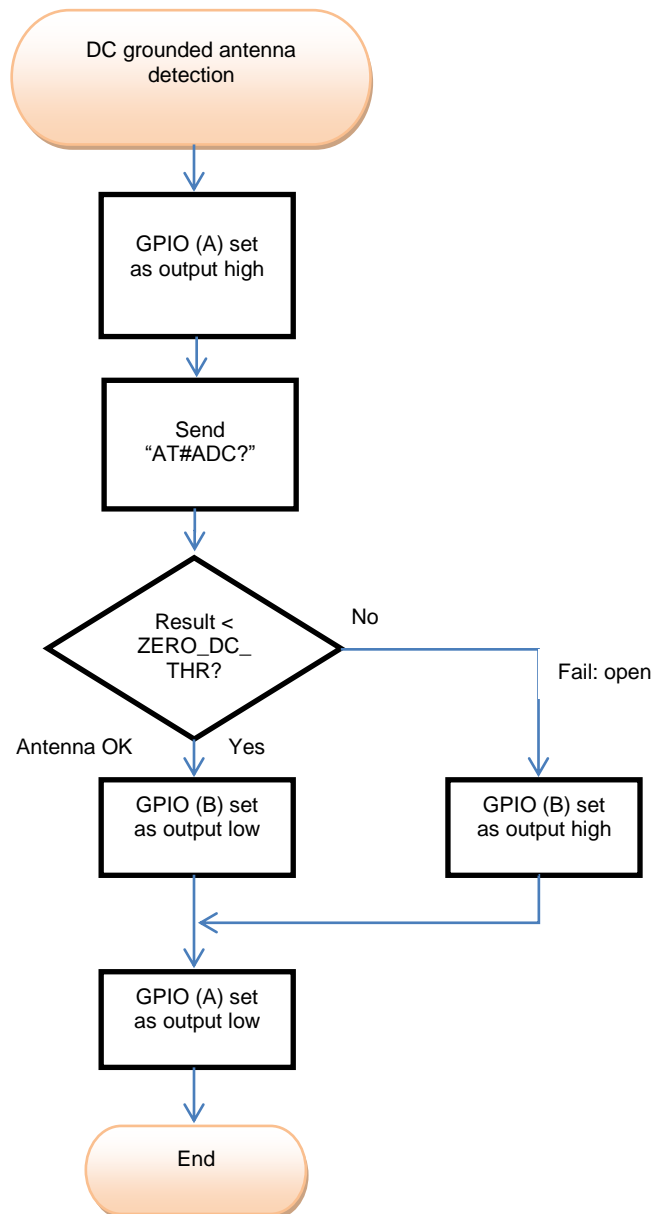

5.3. 10K Ω DC terminated antenna Algorithm

If the chapter 3.3 solution is chosen, the following algorithm is suggested. For algorithms thresholds please refer to Table 5.1.

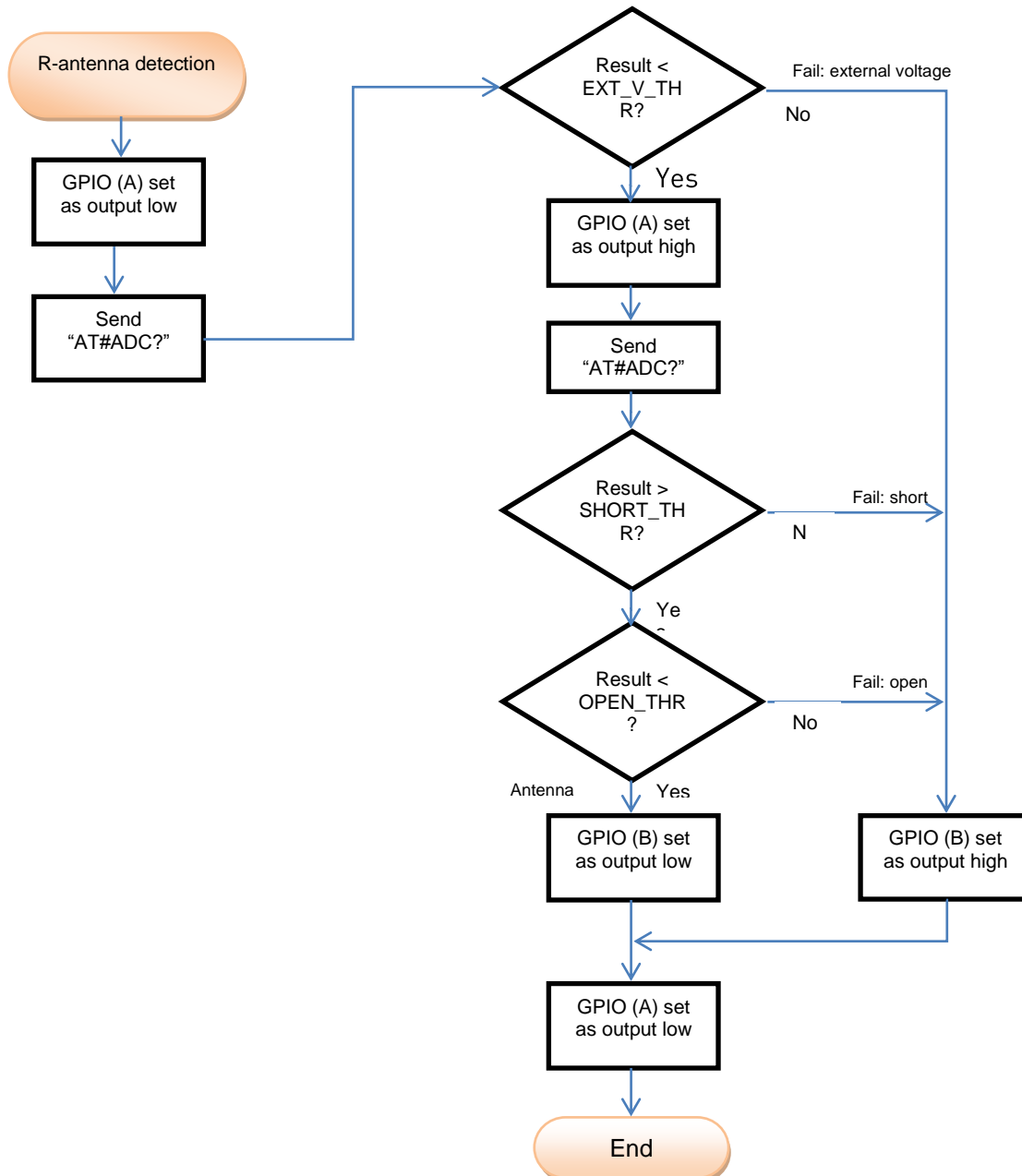

Table 5.1 defines the relevant detection algorithm thresholds, according to M2M module type:

Threshold	Group 1 modules [mV]	Group 2 modules [mV]
EXT_V_THR	400	400
SHORT_THR	265	170
OPEN_THR	1370	880

